

Programmes After Market Services NHP-2 Series Transceivers

11. Car Kits

Contents

	Page No
Car Kits	5
Introduction	5
Unpacking	6
Component Parts	7
Advanced Active Holder MCC-1	7
Advanced Handsfree Unit HFU-2	7
Mounting Plate MKU-1	7
Swivel Mount HHS-9	7
Handsfree Microphone HFM-8	7
Handsfree Speaker HFS-12	8
Power Cable PCH-4J	8
Handset HSU-1	8
External Mobile Antenna (not supplied)	8
Installation.....	9
Ignition Sense IGNS	9
Car Radio Muting CRM	9
Antenna Motor Control AMC	10
Testing	10

Car Kits



Figure 1: Advanced Car Kit (CARK-91). Note: transceiver NOT included.



Figure 2: Advanced Car Kit (CARK-91H) with HSU-1 handset. Note: transceiver NOT included.

Introduction

This installation guide has been prepared to provide the basic information necessary to install car kits. This guide is not intended to be definitive, because different types and models of vehicles will require different installation work. The information given is for general guidance only.

The terms of warranty demand that car kits be installed by an experienced installer and that only genuine Nokia parts are used. An end user should never attempt to install a car kit without professional assistance as the installation requires special tools and knowledge.

Please refer to the telephone's User's Guide for instructions on the telephone's operation, care and maintenance, including important safety information.

Note: Read the following warnings before beginning the installation procedure.

WARNINGS

- 1 ENSURE THAT THE VEHICLE'S BATTERY IS DISCONNECTED BEFORE YOU START THE INSTALLATION PROCEDURE, AND THAT IT REMAINS DISCONNECTED DURING THE PROCEDURE.
- 2 DO NOT SMOKE OR USE OPEN FLAMES WHEN WORKING NEAR THE VEHICLE'S FUEL SYSTEM.
- 3 ENSURE THAT THE VEHICLE'S ELECTRICAL CABLES, HYDRAULIC LINES, FUEL LINES, AND SAFETY EQUIPMENT ARE NOT DAMAGED DURING INSTALLATION.
- 4 ENSURE THAT NORMAL CONTROL AND OPERATION OF THE VEHICLE IS NOT IMPAIRED BY THE INSTALLATION, PARTICULARLY THE BRAKES AND STEERING. ENSURE THAT AIRBAG OPERATION IS NOT OBSTRUCTED.
- 5 ELECTRONIC AND OTHER SOPHISTICATED SYSTEMS (e.g. SPEED CONTROL, ABS ANTI-LOCK BRAKE, FUEL INJECTION, NAVIGATION, AND AIR-BAG SYSTEMS) ARE RELATIVELY IMMUNE TO MALFUNCTION CAUSED BY NEARBY RADIO TRANSMISSIONS. HOWEVER, SHOULD YOU EXPERIENCE FALSE OPERATION OF THESE SYSTEMS OR ARE IN ANY DOUBT WHATSOEVER AS TO THEIR FUNCTIONALITY, PLEASE CONSULT THE VEHICLE'S DEALER.
- 6 THE CAR KIT IS SUITABLE FOR USE ONLY IN VEHICLES WITH A 12 V NEGATIVE GROUNDING. USE ON OTHER SUPPLY VOLTAGES OR ALTERNATIVE POLARITY WILL DAMAGE THE EQUIPMENT.
- 7 THE PHONE SHOULD NOT BE LEFT SWITCHED ON FOR EXTENDED PERIODS WITHOUT RUNNING THE VEHICLE'S ENGINE. FAILURE TO COMPLY COULD DRAIN THE VEHICLE'S BATTERY.

Unpacking

Carefully unpack the equipment and ensure that the following items are present:

- | | |
|------------------------------|-----------------------------------|
| • Advanced Active Car Holder | MCC-1 |
| • Advanced Handsfree Unit | HFU-2 |
| • Power Cable | PCH-4J |
| • Mounting Plate | MKU-1 |
| • Swivel Mount | HHS-9 |
| • Handsfree Microphone | HFM-8 |
| • Handsfree Speaker | HFS-12 |
| • Handset | HSU-1 (only included in CARK-91H) |

Component Parts

Advanced Active Holder MCC-1

The holder allows the phone to be firmly located in a convenient position. The holder is attached to the vehicle's interior using the swivel mount HHS-9. The mounting must be secured with a screw (included with HHS-9). The screw recess can then be covered with the Nokia logo plate.

Product Code

Mobile Holder MCC-1	0620043
---------------------	---------

Advanced Handsfree Unit HFU-2

The handsfree unit enables the phone to operate in handsfree mode. The unit is attached to the vehicle interior using the mounting plate MKU-1. The mounting must be secured with a screw (included with MKU-1). A temporary installation can be achieved using installation belts (not supplied).

Power is supplied from the vehicle's battery via the power cable PCH-4J. The handsfree unit provides the power supply to the phone via the system connector.

The HF microphone HFM-8, connects to the `micsocket`. And the HF speaker HFS-12, connects to the socket.

Product Code

Handsfree Unit HFU-2	0694049
----------------------	---------

Mounting Plate MKU-1

MKU-1 is a fixed-position mounting plate.

Product Code

Mounting plate MKU-1	0620036
----------------------	---------

Swivel Mount HHS-9

HHS-9 is a swivel mount that allows for adjustable fixing. It is an alternative to the MKU-1 method of locating the phone holder, the handsfree unit, or the handset. The two mounting plates are interchangeable.

Product Code

Swivel mounting plate HHS-9	0620037
-----------------------------	---------

Handsfree Microphone HFM-8

The HF microphone connects directly to the handsfree unit (`mic socket`). Insert the plug into the `mic socket` and twist 90° to lock firmly in place.

Product Code

Handsfree microphone HFM-8 0690016

Handsfree Speaker HFS-12

The HF speaker connects directly to the handsfree unit (socket). Insert the plug into the socket and twist 90° to lock firmly in place.

Product Code

Handsfree speaker HFS-12 0692008

Power Cable PCH-4J

The power cable connects the standard handsfree unit HFU-2 to the vehicle's power supply. The red wire must be connected to the + voltage on the vehicle's power supply via the supplied fused connector. The black wire must be attached to a good negative GND connection.

The blue ignition sense (IGNS) wire is connected to +12 V voltage controlled by the vehicle's ignition key via the supplied fused connector. See *Ignition Sense* section.

The yellow wire is used for car radio muting (XCRM). The line goes down to 0 volts during a call. See *Car Radio Muting* section.

The green wire is used for motor antenna (AMC). The voltage in this output is +12 V whenever the phone is on. See *Antenna Motor Control* section.

Product Code

Power cable PCH-4J 0730055

Handset HSU-1

A privacy handset is included with the CARK-91H car kit.

Product Code

Privacy handset HSU-1 0081279

External Mobile Antenna (not supplied)

The cellular phone is designed to operate with a high quality external antenna. However, due to many different types of antennas being available, an antenna is NOT included as part of this kit. Please consult the dealer to find out which is the most suitable antenna type for your installation.

Installation

There are some important aspects that require special attention in positioning car kit accessories.

The positioning of the phone holder is the most important factor when trying to achieve the most comfortable position for the user. The location of the holder should be selected so that the visibility of the phone's display is good under all lighting conditions, but not so that the driver's attention is easily distracted. The holder should be located so that the driver can easily reach the keypad. Under no circumstances should the holder prevent the driver from controlling or operating the vehicle in any way or observing traffic.

The HF microphone should be installed according to the directions in the separate microphone installation guide. Ensure the microphone is as close to the driver's mouth as possible, and attached to a surface that is mechanically quiet. The microphone should be mounted at least 3 ft/1 m away from the handsfree unit speaker to avoid acoustic feedback.

Ensure that cables are routed as far away as possible from the vehicle's electronic systems (refer to WARNINGS)*. Also, ensure that cables are not subjected to undue mechanical stress (e.g. under seats or against sharp edges).

* To prevent disturbance, cables should be routed as far away from the interference source as possible.

Ignition Sense IGNS

The ignition sense feature prevents your car kit from draining the car battery by executing an auto power off in 20 seconds after the ignition key has been turned off. The blue wire of the power cable is used for the ignition sense feature. The use of ignition sense is recommended to prevent accidental draining of the car's battery. The wire is connected via a 1 A fuse to a 12/24 volt potential that is controlled by the ignition key. Do not connect it directly to the high voltage sections of the ignition circuit.

Car Radio Muting CRM

The car kit offers a feature that can mute the car radio automatically during a conversation. This feature is convenient and provides for safer handsfree operation. The car radio muting feature is based on a grounded line, so it means that in standby, the yellow wire (XCRM) is not grounded and car radio works normally, but during a call, line is grounded and car radio is muted. Note that an auxiliary relay or muting unit must be used when the car radio doesn't have a mute feature available.

When a relay is used, connect of series with the car radio main supply. A 200 mA fuse should be used to protect the XCRM output in event of a short circuit. Some radios have separate supplies for amplifiers and motors, and another for memory backup purposes. Very often these radios also have a secret code system, which activates itself if a break in the memory supply is detected. Be careful when installing the relay not to break the memory supply (usually marked ACC or +MEM), but to install the relay in the main supply feed.

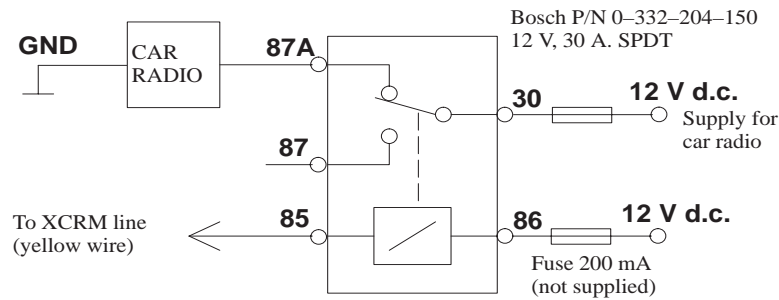

Another possibility is to use a special muting unit, which mutes the radio by connecting load resistors to the speaker lines of the car radio.

Antenna Motor Control AMC

The antenna motor control offers a feature, green wire of the system cable (AMC), that may be used to control different devices on and off. The voltage in this output is +12 V whenever the phone is on. If the phone is turned off, the voltage disappears. The maximum output current is 200 mA; therefore, for example, motorized antenna must be controlled via a relay (see diagram below).

Bosch P/N 0-332-204-150 12 V, 30 A. SPDT

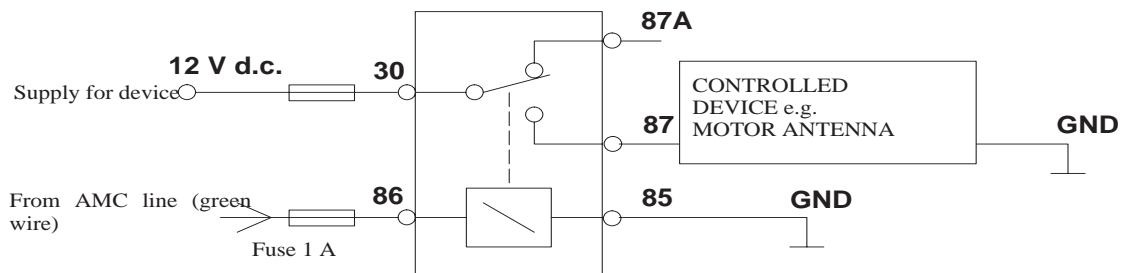

All installations should take into account any special requirements of the customer. However, should the customer require an installation that is illegal or unsafe, these facts must be pointed out to the customer and a policy of noncompliance adopted.

Testing

Once installed, the equipment should be tested to ensure that it is operating satisfactorily and that the position of the units does not impair on the driver's ability to control and operate the vehicle in any way.

Use the phone to make a call when the vehicle is parked with the engine running. During the call, switch off the engine. Ensure that the phone is operational with the engine running and with the engine switched off. For operating information, refer to the User's Guide supplied with the phone.